

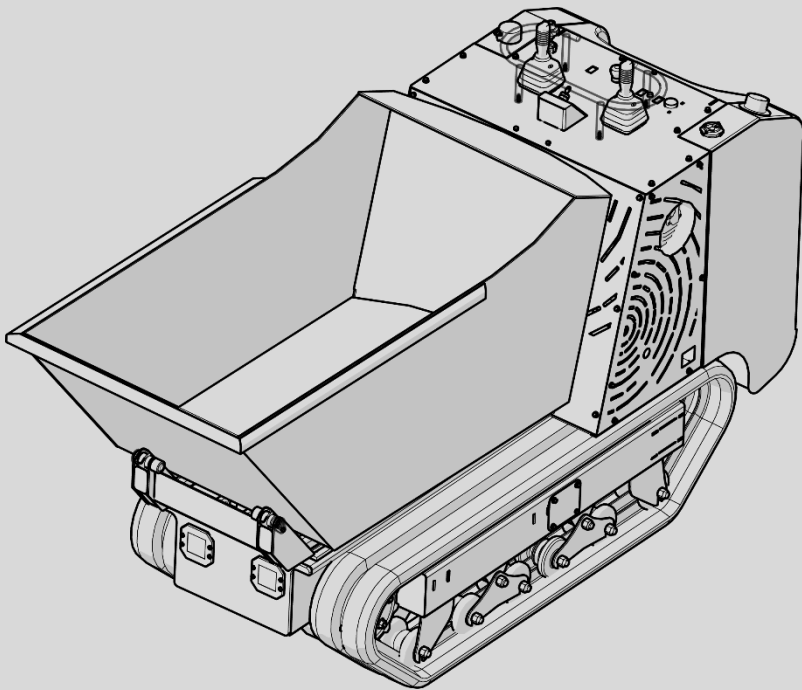

7000MB MEGABUGGY

Owner's Manual



This manual should be kept on hand at all times so that it can be immediately referenced. It should be saved for the entire life of the machine.

© 2022 - The entire or partial reproduction and/or divulging of this document is prohibited in any form without the written consent of the company. The editing of the text, the illustrations, and the paginations were completed by "LHD Machinery, LLC." The illustrations and technical data included in this manual are non binding; *the manufacturer reserves the right to carry out eventual changes to its machine without notice.*

Ed. 4 – 4/20/23

LHD Machinery, LLC
1-888-LHD-7472
LHDmachinery.com

Email / Faxes to:
info@lhdmachinery.com

Find the latest edition of
this Owner's Manual at:
lhdmachinery.com/library



READ MANUAL, PAY ATTENTION TO WARNING STICKERS AND USE EXTREME CAUTION WHEN OPERATING THE MACHINE
FAILING TO COMPLY WITH ANY OF THESE ITEMS CAN CAUSE SERIOUS INJURY OR DEATH

**PLEASE REGISTER YOUR MACHINE ONLINE AT
LHDMACHINERY.COM**

All LHD machines must be registered online after purchase with a serial number and date of purchase. Warranty may be voided without registration.

To register your machine:

- Navigate to LHDMachinery.com
- Locate the "Support" link in the menu and click "Warranty Registration"
- Enter your information, read and confirm that you understand and agree to the terms of the warranty and then submit the form
- Your warranty period will begin on the date of sale and will continue for 1 year or 1000 hours

Table of Contents

Machine and Engine Identification.....	4
Preface	5
Warranty.....	6
Safety.....	7 - 11
Safety Labels	12
Technical Data / Dimensions.....	13 - 14
Startup / Initial Use.....	15
Operation	16 - 21
1. Slopes	8. Automatic Park Brake
2. Loading Bucket	9. Towing
3. Traveling	10. Lifting with Crane
4. Unloading Bucket	11. Lifting with Fork Lift
5. Rotating Bucket and Side Dumping	12. Generator (If Equipped)
6. Throttle Control	13. Auxiliary Tool Circuit (If Equipped)
7. Transporting the Machine	14. Standing Platform
Maintenance Schedule.....	22
Maintenance Directions	23 – 28
1. Engine Oil	7. Hydraulic System
2. Changing Oil Filter	8. Changing Hydraulic Fluid
3. Replacing Air Filter	9. Battery
4. Changing Spark Plugs	10. Cleaning and Long Term Storage
5. Replacing Fuel Filter	11. Tracks
6. Draining Fuel Tank	12. Grease Points
Troubleshooting	29

Machine and Engine Identification

Serial Number of Machine:

Serial Number of Engine:

Purchase Date:

Purchased From:

Dealer Contact:

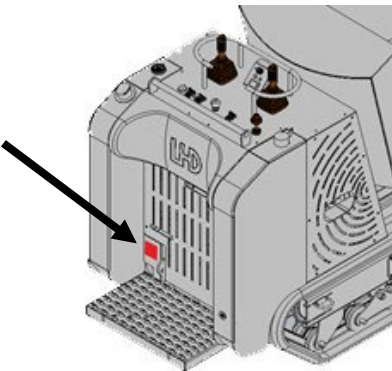

The LHD Serial Number is located on the machine's serial number plate. See the figure to the left for the location of plate on machine.



Preface

Congratulations on your purchase of a LHD 7000MB Mega Buggy!

This manual contains the guidelines for operation and maintenance of this LHD Tracked Buggy series, as well as the corresponding safety recommendations. Please read this entire manual prior to operation to maintain your safety and enhance the performance of the machine.

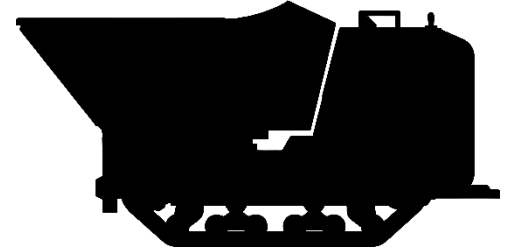

This manual will guide the operator all the rules and precautions needed for operating and maintaining the

machine under the correct safety precautions. Incorrect operation, inspection or maintenance can cause personal injury or even death. **Pay close attention to items marked with this symbol:** 

This symbol a safety concern and give directions for proper use. Potential hazards associated with the operation of this equipment will be referenced with further hazard information which may appear throughout this manual in conjunction with safety symbols.



Reading and use of the manual will help prevent accidents during operation, however, we cannot be held responsible for predicting every kind of danger in all circumstances. The user of the machine is always responsible for paying attention to the machine and its surroundings during operation. Knowledge of this manual and common sense are fundamental in safe use of the machine.



Note: Since our design and manufacturing technology keep improving, future design or improvement may cause the manual to exclude small changes that have been made accordingly. Please contact our company for any information or questions about the machine. Contact information is found on the cover of this manual or can be found on our website. (lhdmachinery.com)

Warranty

LHD Machinery, LLC (“LHD”) warrants that each machine will be free from defects in material and workmanship under normal use for which it was intended for 1 year or 1000 hours. Warranty period begins on first day of purchase by the End User or first day of purchase by a dealer if the machine is intended for rental. Warranty is based on the following limited warranty terms and conditions. It is the responsibility of the user to understand the responsibilities related to the warranty, service and proper operation of the machine.

1. LHD’s obligation and liability under this warranty is expressly limited to replacing or repairing parts if there is determined to be a defect in workmanship or breakage in material. LHD reserves the choice to repair or replace. Parts such as engines, motors, pumps, valves, etc. furnished by us but not manufactured by us will only carry the warranty of their original manufacturer except in special situations as decided upon by the officers of LHD.
2. This warranty does not apply to any failures resulting from: (i) abuse or misuse or improper or unauthorized repair, alteration, maintenance or operation; (ii) accident, natural disaster or act of nature; or (iii) handling, shipping or storage.
3. If LHD chooses to replace the part, it will be at no cost to the customer and will be made available to the LHD Dealer, or Rental Center, from whom the End User purchased the machine or nearest professional repair center. Warranty claims should be reported immediately. Use of the machine after a failure could result in damage and wear not covered under the warranty terms.
4. Replacement or repair parts, installed in the machine, are warranted only for the remainder of warranty period of the machine, as though they were the original parts.
5. LHD’s warranty does not cover the normal maintenance of machines or its components (such as engine tune-ups and oil & filter changes). The warranty also does not cover normal wear and tear items (such as consumables) or ground contact items (such as treads and shovel, if equipped) except in special situations as decided upon by the officers of LHD.
6. LHD does not warranty engines. Engine warranty claims should be made directly to an authorized service center for the particular engine manufacturer. (Please see your engine manual for more details)
7. LHD’s warranty will be void if it is determined that the defect resulted from operator abuse, impact damage, failure to perform normal maintenance, modification, alterations or repairs made to the machine without written approval of LHD.
8. LHD will pay shop labor on warranty items at the LHD Shop Labor Rate in existence on the date of the warranty claim. LHD will determine the time allowed to complete a repair and will govern the shop labor hours that will be allowed.
9. LHD will pay shipping on warranty replacement parts at standard ground rates. No warranty replacement parts will be shipped at any other shipping type or speed at the expense of LHD.
10. LHD’S WARRANTY POLICY WILL NOT COVER THE FOLLOWING: TAXES, SHOP SUPPLIES, ENVIRONMENTAL SURCHARGES, AIR FREIGHT, TRAVEL TIME, LOSS OF TIME, INCONVENIENCE, LOSS OF RENTAL REVENUE, RENTAL COSTS OF EQUIPMENT USED TO REPLACE THE MACHINE BEING REPAIRED, LOSS OF USE OF THE MACHINE, PROPERTY DAMAGE, COMMERCIAL LOSS OR ANY OTHER CHARGES WHATSOEVER OR ANY LIABILITIES FOR DIRECT, INCIDENTAL, OR CONSEQUENTIAL DAMAGE OR DELAY.
11. LHD MAKES NO OTHER WARRANTY, EXPRESSED OR IMPLIED. THERE ARE NO OTHER WARRANTIES THAT EXTEND BEYOND THE DESCRIPTION ON THIS DOCUMENT.
12. No LHD employee or representative is authorized to change this warranty in any way or grant any other warranty unless such change is made in writing and signed by an officer of LHD.

Safety



General Cautions

Read, understand, and follow the instructions in this operator's manual before using the machine.

1. Keep hands, feet and clothing away from all moving parts.
2. Allow only responsible adults who are familiar with the machine and its operation to use the machine.
3. Do not allow any passengers on any part of the machine, including bucket and operating platform.
4. Do not refuel with engine running, or while you, or someone near, is smoking.
5. Do not operate any of the control levers unless you are standing with both feet on the platform and firmly holding the grip handles.
6. Always wear long pants, substantial shoes, gloves, eye, and hearing protection when using the machine. Avoid wearing jewelry or loose fitting clothing.



7. Do not place feet under the platform. Always stand on the platform or to the side of the machine.
8. Watch where you are driving. Always look down and behind, before and while reversing.
9. Engine exhaust contains Carbon Monoxide. This gas is colorless and odorless, and can cause death if inhaled. Do not run the engine indoors or in a confined space.
10. Always stop the engine before leaving the operator's platform.
13. Never jerk the control levers. Use a steady motion. Slow down before turning.
14. Stop the engine before making any adjustments to the machine or any attachments.
15. Never operate the machine in an explosive atmosphere or near combustible materials. An explosion or fire could result causing severe bodily harm or death. Never weld near the fuel tank.
16. Look out for ditches, holes, etc. and beware of traffic when near roads.
17. Do not allow any person or animal close to the machine or its attachments while in operation. Stop the machine if any person or animal comes close.
18. Operate only in daylight or good artificial lighting.
19. Do not operate the machine while fatigued or ill or under the influence of alcohol or drugs.
20. Use extra care while loading or unloading the machine onto a trailer or truck.
21. Do not touch equipment or attachment parts that may be hot from operation. Allow to cool before attempting to maintain, adjust or service.
22. Do not allow children near the machine.
23. Do not use the equipment for any other purposes or application other than its intended purposes.
24. Replace operation and safety decals when they become difficult to read. (Contact LHD for replacements)
25. LHD does not assume responsibility for any accidents due to equipment modifications. Unauthorized modifications will void the warranty.
26. Never use accessories or attachments that are not recommended by LHD for this equipment. Damage to the equipment and/or injury to the user may result.
27. Always know the location of the nearest fire extinguisher.
28. Always know the location of the nearest first aid kit.
29. Always know the location of the nearest phone or keep a phone on the jobsite so that calls can be made quickly in case of emergency.



Remember – Safety is your responsibility.

Safety



Cautions During Operation:

1. All slopes require extra caution. Do not operate on slopes exceeding 10°. If a slope is greater than 10° only go vertically (not horizontally).
2. Always have the heavy end of the machine uphill. Weight distribution will change the tipping point. An empty bucket will make the rear of the machine heaviest, a loaded bucket will make the front of the machine heaviest. These same rules apply when loading and unloading the machine onto a trailer or truck.
3. Avoid turning on slopes. If you must turn, turn slowly keeping the heavy end of the machine uphill.
4. Do not operate near ditches or embankments.
5. Do not operate on wet grass. Reduced traction could cause slippage.
6. Remove obstacles such as rocks, tree limbs, etc. from the work area. Watch for ruts or bumps as uneven terrain could overturn the machine. Tall grass can also hide obstacles.
9. If machine becomes unstable, jump clear. Never try to stabilize the machine yourself.
10. Never use your hand to find hydraulic leaks. Use a piece of wood or cardboard. Hydraulic fluid injected into the skin must be treated by a knowledgeable physician immediately or severe injury or death can occur.
11. Always turn machine off when not in use.
12. Never disconnect any emergency or safety devices. These devices are intended for operator safety. Disconnection of these devices can cause severe injury, bodily harm or even death. Disconnection of any of these devices will void all warranties.
13. Never approach power lines with any part of the buggy unless all local, state/provincial and federal (OSHA) required safety precautions have been taken. Use extreme caution when approaching high voltage power lines.
14. Do not operate the machine at excessive speeds. Reckless operation may cause accidents and severe injury. Slow down when approaching people, wet areas, and going up and down grades. It is the responsibility of the operator to adjust speed, as necessary, depending on the conditions of the road or path.
15. Allow extra time to stop when operating the machine on wet surfaces or loosely graded materials.
16. Do not dump materials that are large, chunky or sticky. These types of material may shift causing the machine to tip and throw the operator off the machine. The machine intended for dumping free-flowing and loose materials such as dry soil, slag, and wet concrete.
17. Do not dump materials from bucket while the power buggy is moving.
18. For walk behind operation, the operator platform must be stowed and locked in the UP position. The speed should also be reduced to 3 mph (4.8 kph) or slower.
19. Always make sure the machine's brakes are working properly. Check brake linkage and adjust as required. Never operate the machine with a defective braking system.
20. Ensure brakes are applied when leaving machine unattended or when using on a slope. When parking on a slope, position the machine at a right angle to a slope. Ensure that the parking brake is engaged and holds the machine safely in place when parking on a slope.
21. When filling or dumping, do not exceed payload capacity of the machine.
22. Do not stand in front, or alongside, the machine when discharging a load.
23. To prevent unexpected loss of control, do not start engine on a sloping surface.
24. Ensure that the speed control works freely and return to the closed position. Do not start engine unless speed control is working properly.
25. Never operate the machine with bad or worn tires. Always replace defective tires with new ones.
26. Always make sure the hydraulic dumping mechanism of the tub is working properly.



Remember – Safety is your responsibility.

Safety



Cautions During Operation:

27. Avoid sudden stops, starts and changes in direction. Operate the controls smoothly. Do not jerk the steering or any other controls.
28. Never attempt to work the controls except from the operator's position.
29. Never drive or tow the machine in traffic or on public roads.
30. Always keep the machine in proper running condition.
31. Fix damage to machine and replace any broken parts immediately.
32. The entire machine should be cleaned after every use. Make sure there is no buildup of concrete, grease, oil or debris on the machine.
33. Always store equipment properly when it is not being used. Equipment should be stored in a clean, dry location out of the reach of children and unauthorized personnel.



Engine Safety:

1. Do not place hands or fingers inside engine compartment when engine is running.
2. Never operate the engine with heat shields or guards removed.
3. Keep fingers, hands, hair and clothing away from all moving parts to prevent injury.
4. Always shut down the engine before performing service or maintenance.
5. Do not remove the engine oil drain plug while the engine is hot. Hot oil will gush out of the oil tank and severely scald any persons close to the machine.
6. Never touch the hot exhaust manifold, muffler or cylinder. Allow these parts to cool before servicing equipment.
7. Never run engine without an air filter or with a dirty air filter. Severe engine damage may occur. Service air filter frequently to prevent engine malfunction.
8. Never tamper with the factory settings of the engine or engine governor. Damage to the engine or equipment can result if operating in speed ranges above the maximum range.



Fuel Safety:

1. Do not start the engine near spilled fuel or combustible fluids. Fuel is extremely flammable and its vapors can cause an explosion if ignited.
2. Always refuel in a well-ventilated area, away from sparks and open flames.
3. Always use extreme caution when working with flammable liquids.
4. Do not fill the fuel tank while the engine is running or hot.
5. Do not overfill tank and tighten fuel cap. Spilled fuel could ignite if it comes into contact with hot engine parts or sparks from the ignition system.
5. Store fuel in appropriate containers, in well-ventilated areas and away from sparks and flames.
6. Never use fuel as a cleaning agent.
7. Do not smoke around or near the equipment. Fire or explosion could result from fuel vapors or if fuel is spilled on a hot engine.
8. Do not leave the machine in the vicinity of ovens, furnaces or radiant heaters. Heat could raise the pressure of the fuel so that vented gas could ignite.

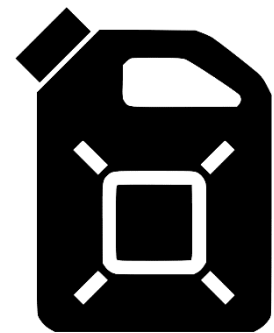

Remember – Safety is your responsibility.

Safety



Battery Safety (Electric Start Only):

1. Do not drop the battery. There is a possibility that the battery will explode.
2. Do not expose the battery to open flames, sparks, cigarettes, etc. The battery contains combustible gases and liquids. Contact with a flame or spark could cause an explosion.
3. Always wear safety glasses when handling the battery to avoid eye irritation. The battery contains acids that can cause injury to the eyes and skin. Use well-insulated gloves when picking up the battery.
4. Do not charge battery if frozen. The battery can explode. Warm the battery to at least 61°F (16°C).
5. Always recharge the battery in a well-ventilated environment to avoid the risk of a dangerous concentration of combustible gases.
6. If the battery liquid (dilute sulfuric acid) is exposed to clothing or skin, rinse skin or clothing immediately with plenty of water.
7. If the battery liquid (dilute sulfuric acid) is exposed to eyes, rinse eyes immediately with plenty of water and contact the nearest doctor or hospital to seek medical attention.
8. Always disconnect the negative battery terminal before performing service on the equipment.
9. Always keep battery cables in good working condition. Repair or replace all worn cables.



Lifting and Maintenance Safety:

1. Never allow any person or animal to stand underneath the equipment while lifting.
2. When lifting of the machine is required, use a properly rated forklift.
3. Never tip the engine to extreme angles during lifting as it may cause oil to gravitate into the cylinder head, making the engine start difficult.
4. Never lift machine to unnecessary heights.
5. Never lift the equipment while the engine is running.



Transporting Safety:

1. Always use ramps capable of supporting the weight of the machine and the operator to load and unload the machine.
2. Always shutdown engine before transporting. Tighten fuel tank cap securely.
3. When transporting the machine is required, place the machine on a flatbed truck, flatbed trailer or equivalent and tie down securely.
4. Always make sure all tie-downs and blocks are in place and the bucket is completely lowered in the flat (horizontal) position.
5. Place chock blocks underneath machine to prevent rolling.
6. When transporting the machine on a truck or trailer, know the overall height to avoid contacting overhead obstructions such as bridges and power lines. Check the truck and ramp capacities.

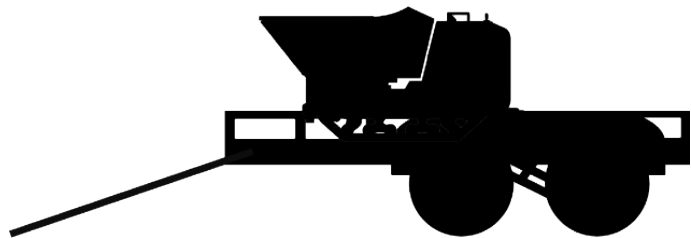

Remember – Safety is your responsibility.

Safety



Bucket Safety

The machine is equipped with a bucket safety bar that will prevent the bucket from lowering under its own weight while performing repairs. To engage the safety bar, use the following procedure:

1. With machine on, raise the bucket
2. Rotate the safety bar into place. (*Fig 1*)
3. With no one under the bucket and all hands free, very slowly lower the bucket down until the safety bar is locked into place.
4. Shut off engine
5. Perform these instructions in reverse when done to remove the safety bar.

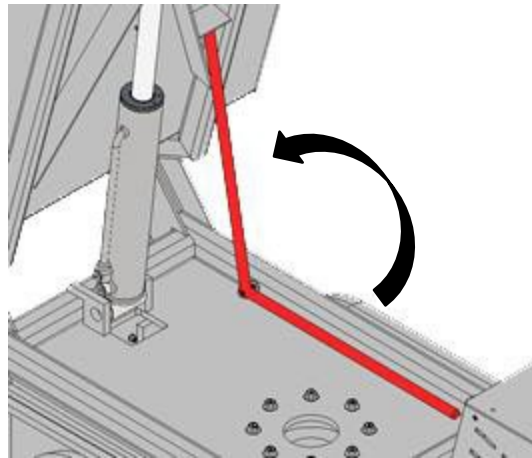

Fig 1 – Bucket Safety Bar



Remember – Safety is your responsibility.

Safety Labels

On the machine there are various signs and labels that provide information on safety. Below is a list of those labels and their corresponding descriptions. Be sure that all safety labels remain clean and legible

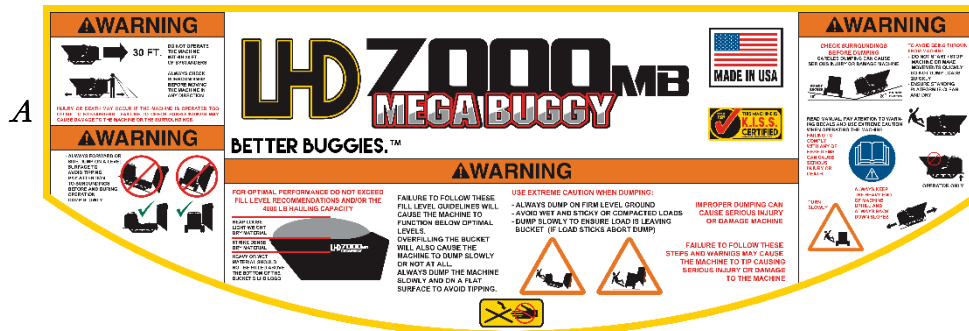

Decal A:

- Do not operate machine within 30 ft. of bystanders.
- Visibility Hazard: Look before backing up.
- Use extreme caution when dumping – Always dump or side dump on level ground, avoid wet and sticky loads, dump slowly to ensure load is leaving bucket (if load sticks abort dump)
- For optimal performance, follow fill level recommendations.
- Use extreme caution when dumping.
- Do not run the machine on vertical slopes more than 10 degrees / horizontal slopes more than 10 degrees.
- Always keep heavy end of machine uphill.
- No Persons Allowed in Bucket (Operator Only)
- Do not start or stop the machine quickly or dump loads too quickly. Ensure the platform is clean and dry or the user may be thrown from the machine.
- Turn slowly to avoid being thrown from machine.
- Always keep the heavy end of the machine uphill and back down slopes.

Decal B: Do not operated Aux/Generator Controls while machine is in motion.

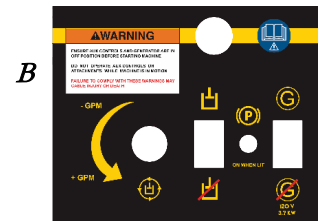

B



C

Decal C:
Gas Only
Allowed
in Engine



E

Decal E:
Caution / Hot – Do
Not Touch

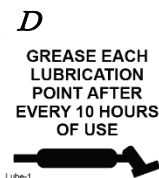

D

Decal D:
Grease Each
Lubrication
Point After
Every 10
Hours of Use



F

Decal F:
Danger of Pinching



G

Decal G:
Hydraulic Fluid Only
(No Other Fluids)

Technical Data

The LHD 7000 MB is a universal material hauler intended for the transportation of any bulk material. This machine is also designed for many other construction and landscaping applications such as job site cleanup and supply transport.

The LHD 7000 MB is equipped with a metal bucket with a capacity of 27 cubic feet, or 1 yard, which allows users to move more material in less trips. The 6-inch dump height and wide 9 in (228mm) tracks also allow users to navigate most any terrain. The design of the machine is balanced with a low center of gravity for safety.

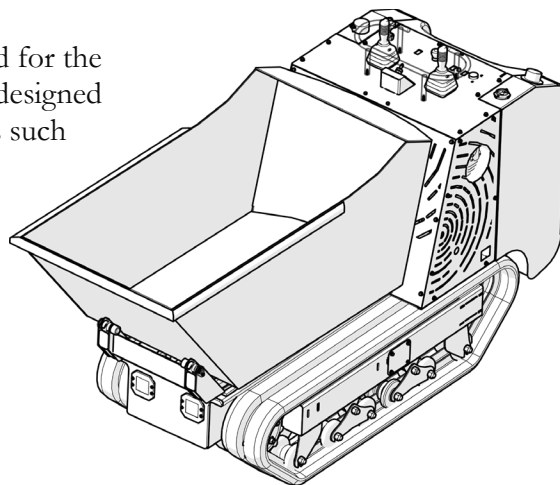

The 9 gallon (34.5 liters) fuel tank allows for prolonged use without interruption and the powerful engine and Poclain hydraulics allow for a maximum speed of 5 mph when empty.

The maximum weight capacity of the LHD 7000 MB is 4,000 lbs. (1,814 kg), the machine can pass through a 36 in. standard door width.

Easy hand controls in reach from the safety handlebar allowing the user to keep their hands on the machine for stability. Multiple lift and tie down points have been provided.

The LHD 7000 MB Mega Buggy is powered by a Kohler ECH740 EFI air cooled gasoline engine rated at 26.5 HP at 3600 RPM.

This machine's hydraulic system uses a closed loop configuration, operating at a maximum of 5000 PSI on the track drive motors and 3000 psi on everything else. The system also features an automatic parking brake when the machine is turned off. In the event of a break down the automatic parking brake would need to be released to be "towed" or "moved". The hand pump is located inside the exhaust panel.

The hydraulic oil is filtered by a screen type filter located in the hydraulic tank, then doubled filtered within the system by a 10 micron cartridge spin-on return filter.



Important Caution: Read this manual and your engine manual fully before operating or maintaining the machine. Pay special attention to the warning stickers on the body of the machine. It is of extreme importance to follow any warnings or instructions described in the manuals or by the stickers on the machine. Always use common sense for maintenance and use, otherwise property damage, personal injury or death may occur.

Technical Data

Engine	Kohler ECH749
Horse Power	26.5 HP
Fuel	Gasoline
Starter	Electric
Speed (empty, loaded)	3-4 MPH, 4.8-6.4 KPH
Bucket Capacity	27 Cu. Ft
Payload	4,000 LBS
Dump Angle	85°
Weight	2850 lbs
Aux Tool GPM (if equipped)	12 GPM at 2500 PSI

Dimensions

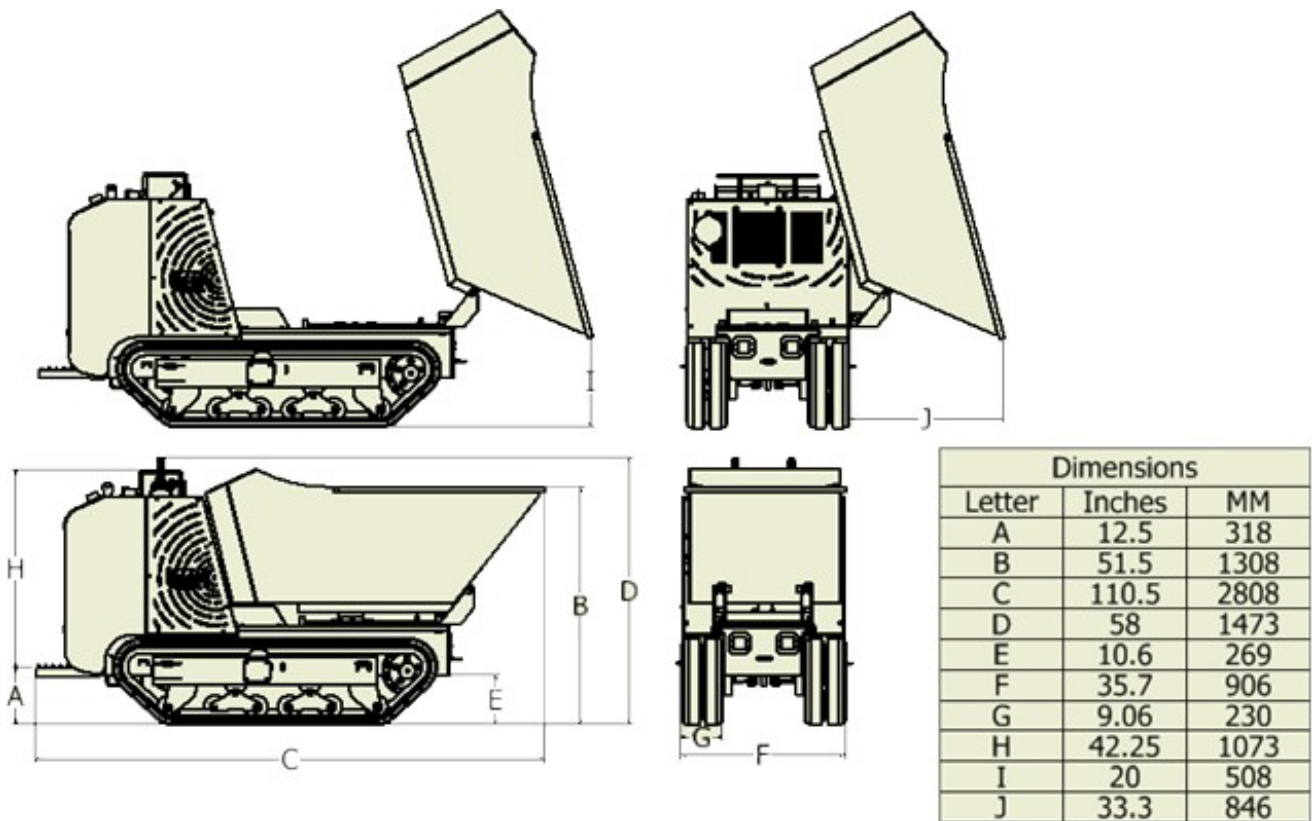

Startup

Please read the entire Instruction Manual carefully before putting the machine into use. This also includes the warning labels on the machine. Any operation in contradiction with these instructions or warning may result in personal injury.

Check if the surroundings of the machine are safe and if there are any objects or foreign matter between the moving parts. If the machine is started under such conditions, it may cause damage of the machine or result in injury.

To keep machine in a good operative state, it is required to check these items EVERYDAY:

- Engine oil level
- Tension of tread and status of each working wheel
- Level of hydraulic oil and fuel (also check for leakage and tighten connections)
- Lubricating points of each sliding position (replenish lubricating oil if needed)
- Tightness of bolts

Note: If the engine seems difficult to start see the troubleshooting section of this manual.

- **For Cold and Warm Start:** This machine is electronically fuel injected. Therefore, it does not have a choke and should start similar to a car. If the engine will not start refer to the engine manual.
- To turn machine off, turn key back to OFF position.

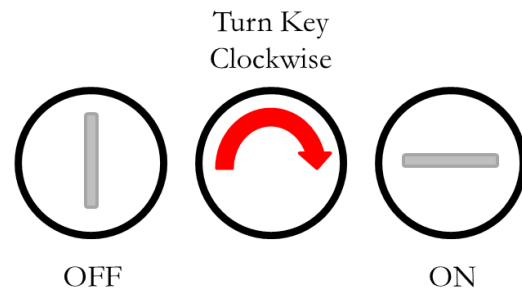

Initial Use

Before their sale, all machines have been tested and inspected. However, during the first 10 hours of use it is recommended that you pay close attention to a few items to ensure successful, efficient and safe operation. If the machine is run improperly or if these directions are not followed the machine's lifespan will shorten and working efficiency will be reduced.

It is the responsibility of the owner to follow these directions **during the first 10 hours of use:**

- Let the machine warm up at least 5 minutes after start up.
- Avoid using full speed to drive the machine.
- Never start or accelerate the machine hastily; avoid unnecessary emergency stops or turning abruptly.
- Clean engine oil filter. (See manual of engine for instructions)
- Check all hydraulic connections (including on engine) and tighten when needed.

Operation

1. Slopes



Caution: Always avoid site conditions with slopes that are greater than the slopes in (Fig 2) or include loose soil conditions. There is a possibility of overturning the machine with serious injury or death of the operator. Always avoid working on terrain with slopes that are greater than those prescribed. In every case, but especially when working on slopes, it is important that the terrain is solid and stable.

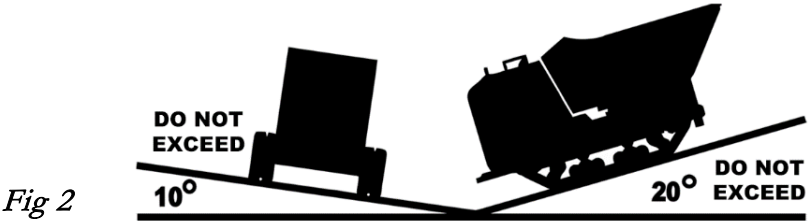

Caution: Always keep the heavy end of the machine uphill and always back down slopes. (Fig 3)

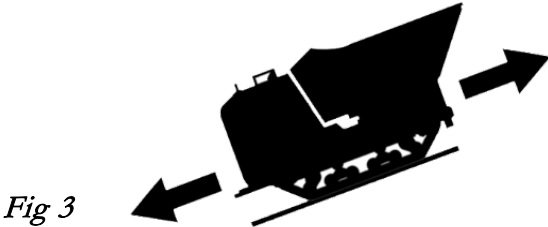

Caution: Never dump on a slope or soft soils. (Fig 4)

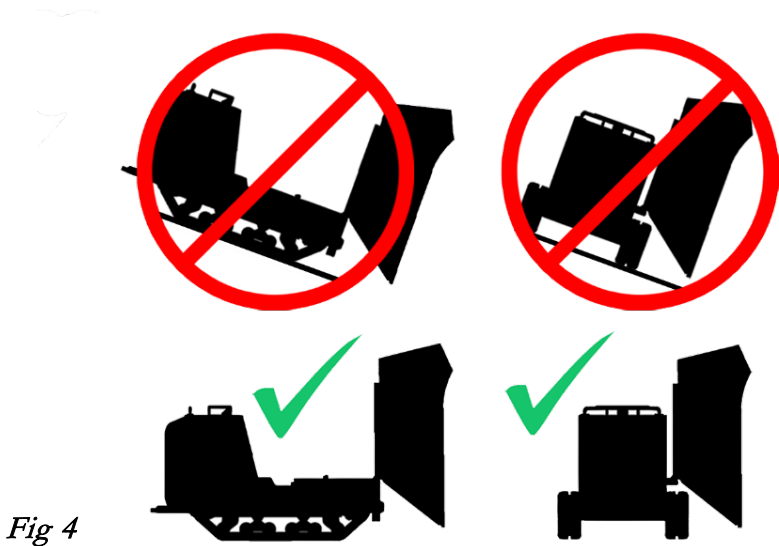

Operation

2. Loading Bucket

For safety and optimal performance do not exceed fill level recommendations and/or the 4000 lbs hauling capacity. (Fig 5)

Fig 5

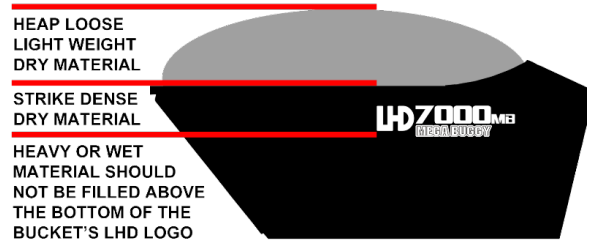

3. Traveling

Note: The horn is the top button of the drive control.

After the engine starts, you should operate the joystick as shown in the figure to the right (Fig 6) to drive the machine. Push the joystick forward to move forward and pull backward to move back. The more pressure put on the joystick, the higher the speed.

To turn: While stopped, slowly push the joystick to the right to turn right; push the joystick to the left to turn left. To turn while driving, push the joystick in the direction you would like to travel.

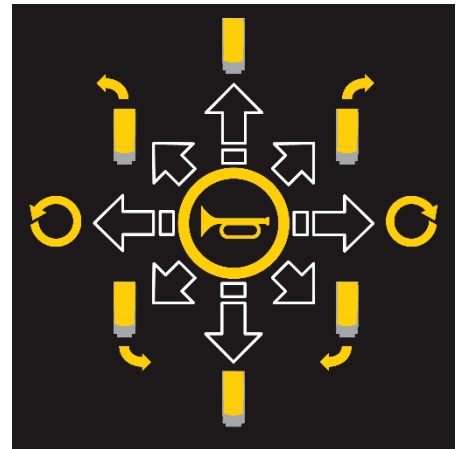

Fig 6



Caution: Never run the machine too quickly when moving or turning. This causes a risk of throwing the user off the machine and causing injury or death. Never steer on a slope or on unstable ground. This could cause the machine to overturn. Take precautions when traveling across a slope. Always move in directions parallel with the slope.

4. Unloading Bucket

Operate the joystick as shown. (Fig 7) Push the joystick forward slowly to dump the bucket. Pull the handle backward slowly and it will return the material bucket to its original position.

To unload: After the material bucket is filled, drive the machine to the discharging area. Dump the bucket SLOWLY. Driving the machine backward after dumping may help empty the bucket.

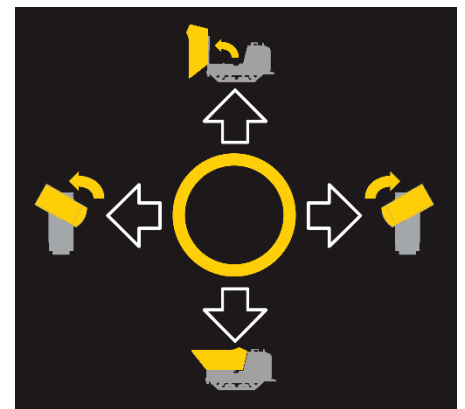

Fig 7

5. Rotating Bucket and Side Dumping

Operate the joystick as shown. (Fig 7) Push the joystick to the right to rotate the bucket right. Push the joystick to the left to rotate the bucket left. Be sure to re-center the bucket to dump straight forward again

Operation



Caution: While side dumping, or dumping straight, if the load is sticky (such as wet soil) the user may need to help remove the load from the bucket. Turn off the machine and check its surroundings before you help unload. Dump slowly to ensure load is leaving bucket, if load sticks about the dump.



Caution: Be the utmost aware when dumping the bucket to the side. (*Fig 8*) Ensure all persons are a safe distance away, 30 feet or more. Never side dump the machine with other than 2500 lbs or less of loose easy to remove materials. Never dump the machine on a declining slope. Look for barriers when dumping.



Fig 8

6. Throttle Control

Operate the throttle control knob as shown in the figure to the right. (*Fig 9*) Rotate the knob to the left to throttle up (rabbit) and rotate the knob to the right to throttle down (turtle). Throttle can also be controlled on the engine itself.

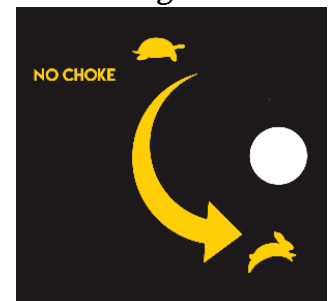

Fig 9



Caution: Always operate the machine at the appropriate speed. Operating the machine at too high of a speed can lead the user to being thrown off the machine or the machine tipping over. Use extreme caution when using the machine at high speeds.

7. Transporting the Machine

Loading and unloading the machine from vehicle or trailer:

- Always load and unload the machine on a level surface.
- Always use ramps that are sufficiently strong, wide and long for the machine.
- Ensure that the hauling surface and ramps are clean and not slippery. (Never steer on ramps)

Transporting:

- Secure the machine to the vehicle or trailer tightly using fastening devices and the 6 tie down points. (*Fig, 10, 11, and 12*) Figure 12 shows tie down location under the rear of machine. Ensure that the machine will not roll or shift on its own.

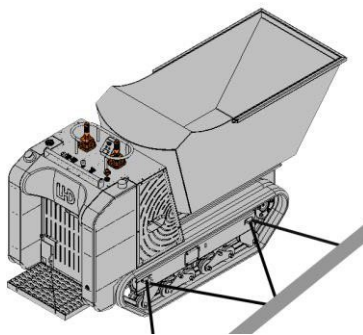

Fig 10

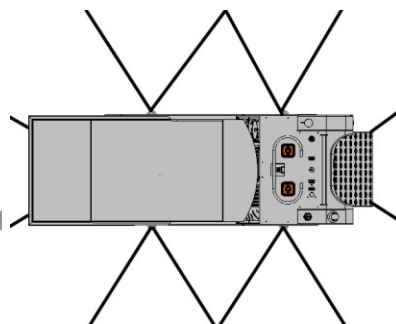

Fig 11

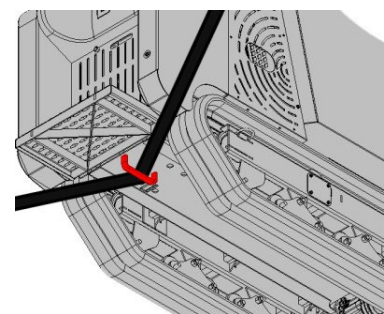

Fig 12

Operation



Caution: Never transport the machine unless you are sure that it is secured sufficiently to the transport vehicle. Before leaving the machine unattended, always turn it off. Check that all locking devices are in the correct position.

8. Automatic Park Brake

This machine is equipped with an automatic park brake. (*Fig 13*) The park brake is intended to eliminate accidental movements when there is no operator present. When the engine is started and everything is working properly the park brake is released. When the engine is off the park brake is automatically set. If equipped with the generator or auxiliary tool circuit, the park brake is also automatically set when in use. If the machine engine fails to start, or there is a malfunction with the pump, the park brake will not be released and you may wish to deactivate it.

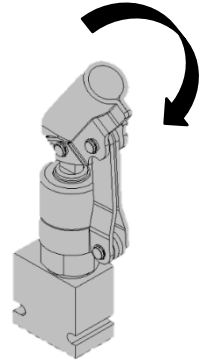

Fig 13



Caution: Park the machine on a flat, level and stable surface. If parking on an uneven surface is unavoidable, turn the bucket straight, apply the park brake and block the tracks at the lower end of the machine. Without a load, park the machine with the operator's step uphill. With a load, park the machine with the operator's step downhill (Never park sideways on a slope.) In order to deactivate the park brake the park brake pump must be used. **Locate the park brake pump inside the left side panel next to the muffler** and pump until there is enough pressure to release. While towing, pressure may drop. Continue to pump the park brake release pump until the machine has reached a different destination.

9. Towing

After the material has been removed from the bucket and the park brake has been released, use the D ring located on the front bumper and connect a strong tow strap. (*Fig 14*) While towing, if the tracks start to spin continue to pump the park brake release pump until you reach your destination. (**See Automatic Park Brake Above**)



Fig 14

10. Lifting with Crane

The machine is equipped with 4 D rings for lifting. Ensure the bucket is empty and no person is near the machine while lifting. (*Fig 15*)

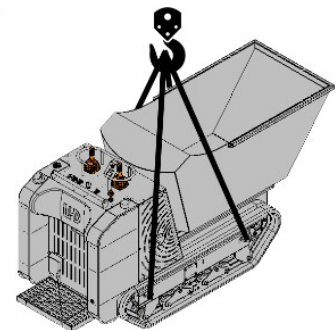

Fig 15

Operation

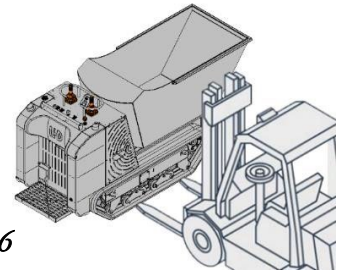

Fig 16

11. Lifting with Forklift

The machine can be lifted from the rear or the sides, not from the front, with a forklift. To lift from the rear, adjust the forks so they are 16' 5" apart (from the outside). Raise the rear platform of the machine. Use caution not to cause damage to the tanks while the forklift is going towards the machine

To lift the machine from the side, place the forks through the frame (Fig 16) by placing the forks 33" apart (from the outside). Ensure the forks extend to through the other side of the machine before lifting. With both lifting techniques, make sure bystanders are clear, move slowly and always keep machine as close to the ground as possible.

12. Generator (If Equipped)



Caution: Never operate an electric tool while driving machine. No operator should be on the machine during the time of electric tool use. Doing so can result in serious injury or death. After the generator is turned on, the park brake is automatically set. Turn on the generator by using the switch on the control panel marked with "G" symbol. (Fig 17) After setting park brake you can begin to use the generator. You can use up to 3.7 KW. Please see generator owner's manual for more information.

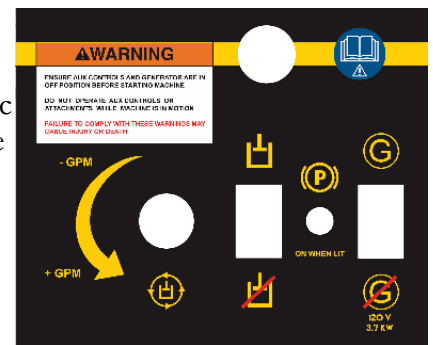

Fig 17

13. Auxiliary Tool Circuit (If Equipped) (Fig 18)



Caution: Never operate a hydraulic tool and drive the machine at the same time. No operator should be on the machine during the time of auxiliary tool use. Doing so can result in serious injury or death. After the tool circuit is turned on the park brake is automatically set. **Note:** Auxiliary Tool Circuit may not operate all hydraulic tools properly. Only up to 12 GPM at 2500 PSI.

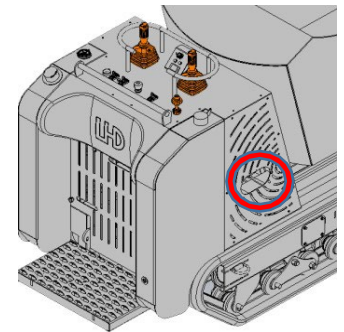

Fig 18

Before connecting implement hoses to tool circuit, determine which hose connects to each port.

1. Connect hoses with engine off and adjust the Aux Flow Knob to its lowest setting by rotating clockwise. (Fig 17)

2. Start the engine and turn on the Aux Flow circuit by using the switch on the control panel with the hydraulic symbol, next control the generator switch and aux flow knob. (Fig 17) At this time the park brake is automatically set.

Note: If the engine struggles to start or won't start check your tool hose connections.

3. Slowly increase the engine RPM

4. Adjust the Aux Flow Control knob to get the desired performance from the hydraulic tool by rotating the knob counter clockwise.

5. After tool use, decrease the Aux Flow and decrease the engine RPM down to idle.

6. While no one is handling the hydraulic tool flip the Aux Tool switch to off (Fig 17) and then turn off the machine. Try to activate the tool to reduce built up pressure and remove the hoses. Turn on the auxiliary tool circuit by using the switch on the control panel. (Fig 17)

Operation

14. Standing Platform

To lower the standing platform, pull the pin at the bottom right side of the platform out towards the right side of the machine. (*Fig 19*) When lowered it locks into place but still has some movement. To raise the platform, pull the pin towards the right side of the machine and raise. The platform will lock into place once raised all the way.

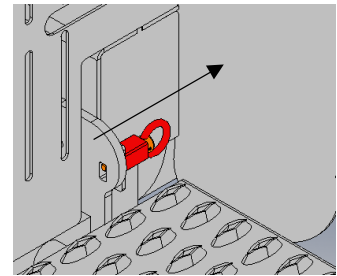

Fig 19



Caution: Hard or sharp objects may scrape the tread and reduce service life. Corrosive fluid may also damage the tread. If spilled onto the tread or run over on the ground clean the tread immediately.



Caution: If the machine is not to be used for an extended time (3 months or more) store machine in location where the tracks are not in direct sunlight or weather.

Maintenance Schedule

Regular maintenance should be conducted. Maintenance is essential to warrant long life of the machine. Below is a general overview of the maintenance schedule to guide maintenance and proper techniques. Please see your engines owner’s manual for a more specific maintenance routine. Maintenance work can be dangerous if it is not done safely. Anyone working on the machine should understand all hazards and follow safety procedures. Prior to any maintenance work, turn OFF the engine and block the machine to prevent any movement that could cause harm to the operator.

Item	Maintenance Requirements	Weekly	Frequency HRS						
			2 5	5 0	1 0 0	2 0 0	2 5 0	5 0 0	1 K
Engine Oil	Check the oil level; Add engine oil if necessary (see Engine Manual)	X							
Engine Oil and Fuel Filter	Replace engine oil filter and fuel filter				X				
Air Filter and Air-Inlet System	Check for damaged components or if the components are blocked / Replace when necessary (see Engine Manual)		X						
Treads	Check if there are loose fasteners; Check the tension; The tread can be tightened by adjusting the tensioning bolt	X		X					
Grease Points	Keep All Grease Points Lubricated	X							
Hydraulic System	Check hydraulic oil level; Inject oil when necessary; Check if there is a leakage or damage; Repair or replace the sealing components and hoses when necessary		X						
Spark Plugs	Check and clean spark plugs				X				
Spark Plugs	Replace spark plugs and set gap							X	
Crankshaft Spline	Have spine lubricated by an authorized engine dealer							X	
Hydraulic Oil Tank	Replace the hydraulic oil and filter							X	
Battery	Replace Battery								X



Caution: Always keep the machine clean. Remove any dirt or grease and never leave anything flammable in the working area of the machine. No smoking is allowed when filling oil or fuel.



Caution: If there is any abnormal sound when the machine is in use, it should be stopped immediately for inspection or maintenance. Always shut down machine before maintenance.

Maintenance Directions

1. Engine Oil

Refer to Engine Manual for required frequencies of oil changes, oil types, and viscosity.

Changing/ Draining oil

1. Start the engine and let it run for 5 minutes.
This warms the oil so it will drain better.
2. Park the machine, turn the key to “OFF” to stop then engine. Remove the key.
3. Pull the oil drain hose through the bottom plate and towards a pan. Remove bung by turning counter clockwise while holding the nut. Allow to drain fully.
4. Replace the bung and push the oil drain hose back up through the hole in the frame. **(Fig 20)**

Note: Dispose of used oil in accordance with local authority regulations.

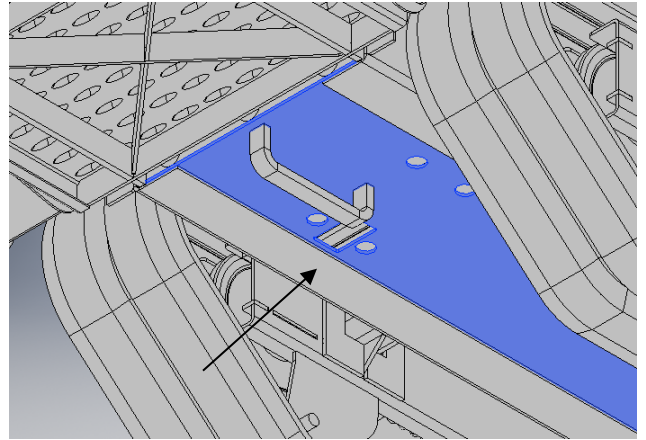

Fig 20

5. Slowly pour approximately 80% of the specified amount of oil (refer engine manual) into the filter tube. Now check the oil level. Slowly add oil to bring to “FULL” mark on dipstick.

2. Changing Engine Oil Filter

1. Remove the cover plate directly across from the oil filter. If not, you will not have enough room to remove the filter. Refer to engine manual for type of oil filter. **(Fig 21)**

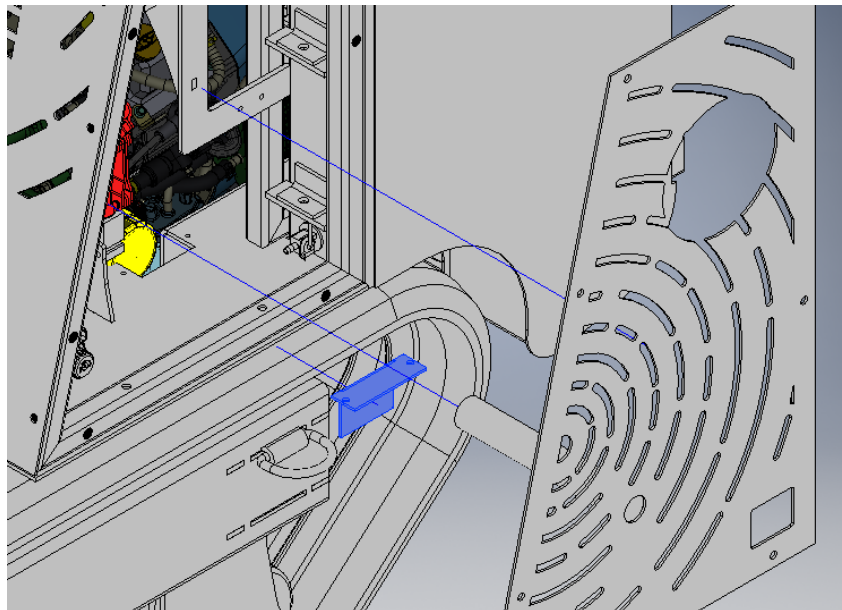

Fig 21

Maintenance Directions

3. Replacing Air Filter

1. (Fig 22) The machine has two cylindrical air filters, one inside the other. Remove the back panel of the machine using the four thumb screws. On the left side of the engine remove the air filter cover. Due to space constraints you must remove both air filters at the same time, outer and inner. Grab the large outer most air filter and gently wiggle up and down while slowly pulling it to the left side of the machine. This motion should also loosen the inner most air filter. Reverse the instructions to insert a new filters.

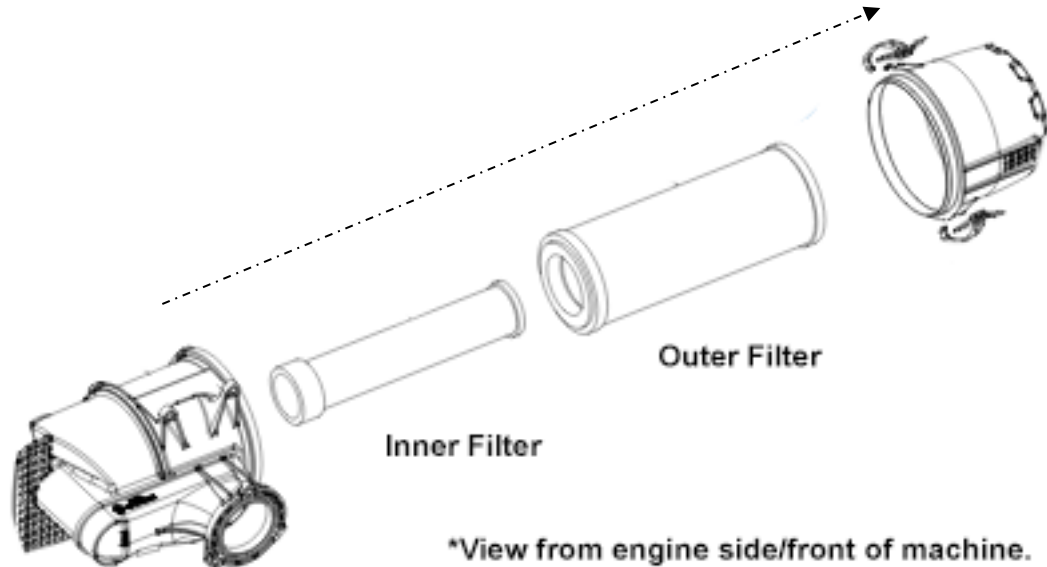

Fig 22

4. Changing Spark Plug(s) - Refer to engine manual.

5. Replacing Fuel Filter

Replace the fuel filter after every 100 operating hours or yearly, whichever occurs first.

1. Never re-install a dirty filter.
2. Lower the bucket and turn the key to "OFF" to stop the engine. Remove the key.
3. Close the fuel valve to block fuel flow.
4. Squeeze the ends of the hose clamps together and slide them away from the filter.
5. Put a drain pan under the fuel lines to catch leaks, then remove the filter from the fuel lines.
6. Install a new filter and move the hose clamps close to the filter.
7. Remove clamp blocking fuel flow.

Maintenance Directions

6. Draining Fuel Tank



Caution: Fuel is extremely flammable and highly explosive. To avoid a fire or explosion drain fuel from the fuel tank when the engine is cold and complete the task outdoors. Never drain fuel near an open flame or where a spark may ignite fuel fumes. Never smoke while handling fuel.

1. Park the machine on a level surface, to assure fuel tank drains completely. Then lower the bucket and turn the ignition key to “OFF” to stop the engine. Remove the key.
2. Close the fuel valve. Loosen the hose clamp at the fuel filter and slide it up the fuel line away from the fuel filter.
3. Pull fuel line off fuel filter. Open the fuel valve, and allow fuel to drain into proper container.
4. Remove tank from the machine by undoing the fasteners. Hold the tank from inside the frame. Remove tank. Drain completely and flush by tipping tank upside down.
5. Reverse procedure to replace clean tank.
6. Install fuel line onto fuel filter. Slide hose clamp close to the fuel filter to secure fuel line.

7. Hydraulic System

Replacing the Hydraulic filter

Change the hydraulic filter after every 300 operating hours or earlier pending on environment. (Fig 23)

1. Position the machine on a level surface, lower the loader arms and turn the key to “OFF” to stop the engine. Remove the key.

IMPORTANT: Do not substitute automotive oil filter or severe damage may result.

2. Remove the old filter and wipe the filter adapter gasket surface clean.
3. Apply a thin coat of hydraulic fluid to the rubber gasket on the replacement filter.
4. Install replacement hydraulic filter adapter. Tighten clockwise until the rubber gasket contacts the filter adapter, then tighten the filter an additional ½ turn.
5. Clean up any spilt fluid.
6. Start engine and let run for about two minutes to purge air from the system. Stop the engine and check for leaks.
7. Check fluid level in hydraulic tank and add oil to raise level to mark on dipstick.

DO NOT OVER FILL.

Note: The correct level is 3 inches below the top of the tank.

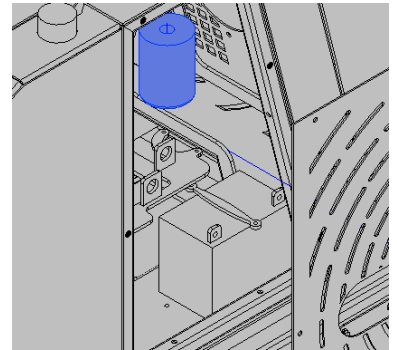

Fig 23

Maintenance Directions

8. Changing Hydraulic Fluid

Note: Change the hydraulic fluid: After every 500 operating hours

1. Position the machine on a level surface, lower the loader arms and turn the key to “OFF” to stop the engine. Remove the key.

IMPORTANT: Do not substitute automotive oil filter or severe damage may result.

2. Place large drain pan under the machine that can hold at least 18.5 gallons.
3. Remove the drain plug from the bottom of the hydraulic tank and allow the fluid to completely drain out. (Fig 24)
4. Remove the tank top and wipe out the inside of the tank.

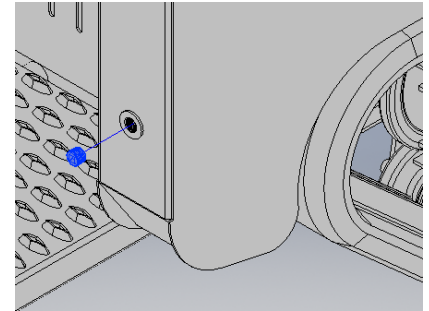

Fig 24

Note: If any foreign matter is found, contact LHD, your service center or a hydraulic expert.

5. Install the drain plug.
6. Fill the hydraulic tank with approximately 57 liters of H68 Hydraulic oil.

Note: Dispose of used oil in accordance with local authority regulations.

Check Hydraulic Lines

Check hydraulic lines after every 100 operating hours, check hydraulic lines and hoses for leaks, loose fittings, kinked lines, loose mounting supports, wear, weather and chemical deterioration. Replace all moving hydraulic hoses every 1500 hours or two years, whichever comes first. Make necessary repairs before operating.



Caution: Hydraulic pressure escaping under pressure can penetrate the skin and cause injury. Keep hands and body away from pin hole leaks or nozzles that eject high pressure hydraulic fluid. A small leak can be dangerous. To find hydraulic leaks, use cardboard or paper. If fluid is accidentally injected into the skin contact a doctor immediately.

9. Battery

Always keep the battery clean and fully charged. Use a paper towel to clean the battery case. If the battery terminals are corroded, clean them with a solution of four parts water and one-part baking soda. Apply a light coating of grease to the battery terminals to reduce corrosion.

Note: Battery Voltage: 12 v

If battery dies or machine is not used for a long period, charge the battery using an external battery charger. Do not rely on the engines charging system to recharge a battery. It is only meant to maintain charge in a good battery.

Maintenance Directions

10. Cleaning and Long Term Storage

1. Lower and center (if equipped) the bucket and turn the key to “OFF” to stop the engine. Remove the key.
2. Remove dirt and grime from the external parts of the entire machine, especially the engine.

IMPORTANT: You can wash the machine with mild detergent and water. Avoid excess use of water, especially near the control panel, engine, hydraulic pumps and motors.

3. Service the air filter.
4. Change engine oil; refer to engine manual.
5. Remove spark plug(s) and check its condition; refer to section on Spark Plugs. With spark plug(s) removed from the engine, pour two tablespoons of engine oil into the spark plug hole. Now use the starter to crank the engine and distribute the oil inside the cylinder. Install the spark plug(s). Do not install the wire on the spark plug(s).
6. Check condition of treads and tighten if necessary; refer to section on treads.
7. Charge the Battery; refer to section on Batteries.
8. For long-term storage (more than 90days) add stabilizer/conditioner additive to fuel tank.
 - A. Run engine to distribute conditioned fuel through the fuel system (5 minutes).
 - B. Stop engine, allow to cool and drain the fuel tank; refer to section on Fuel Tank.
 - C. Restart engine and run it until it stops. Repeat, on “CHOKE” until engine will not restart.
 - D. Dispose of fuel properly. Recycle according to local codes.

Note: Do not store stabilized/conditioned fuel over 90 days.

9. Check and tighten all bolts, nuts, and screws. Repair or replace any part that is damaged or defective.
10. Store the machine in a clean, dry garage or storage area. Remove the key from the ignition switch and keep it in a memorable place. Cover the machine to protect it and keep it clean.

11. Tracks

- Adjust the track tension weekly to ensure sufficient tightening
- Insufficient tension quickly wears out the tracks
- Excessive tension produces resistance which can cause excessive wear or possible breakage

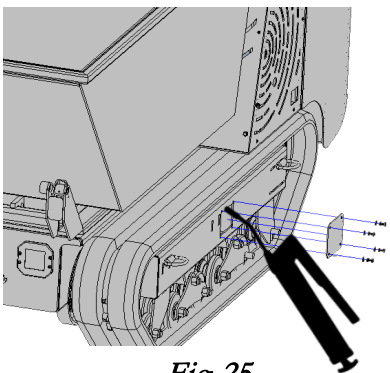

Fig 25

To prevent damage to rubber tracks avoid working on extremely rough terrain and using aggressive movements.

Tensioning Tracks:

1. Remove the tensioner access plate on the side of the tracks. **(Fig 25)**
2. Using a grease gun pump to insert the grease.
3. Tighten nut.

Maintenance Directions

12. Grease Points

Check grease points every 10 hours of use. There are 33 total. Each track roller has 24 total grease points, the dump cylinder has 2, slew drive has 5, and the bucket pivot has 2. General locations show below. (*Fig 26*)

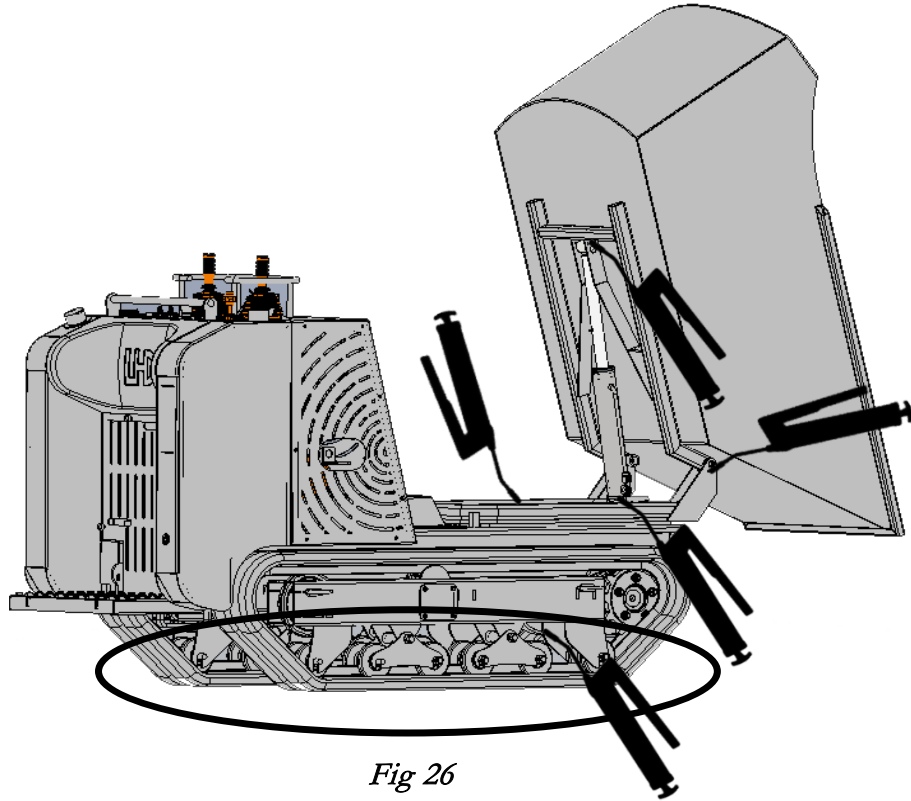

Fig 26

Troubleshooting

	Possible Cause											
	No Fuel	Improper Fuel	Dirt in Fuel	Incorrect Oil Level	Engine Overload	Dirty Air Filter	Faulty Spark Plug	Tighten/Check Tracks	Excessive Oil Temp	Grease Points	Turn off Aux and Gen Switch	Emergency Stop Button is activated
Will Not Start	x	x	x	x	x	x	x		x		x	x
Hard Starting		x	x	x	x	x	x		x		x	
Stops Suddenly	x		x	x	x	x	x		x		x	x
Lacks Power		x	x	x	x	x	x			x	x	
Engine Oil Leak				x	x				x			
Operates Erratically		x			x	x	x					
Knocks or Pings		x			x		x					
Skips or Misfires		x	x			x	x					
Backfires		x	x		x	x	x					
Overheats		x	x	x	x	x						
High Fuel Consumption					x	x	x			x		
Hydraulic Oil Leak				x					x			
Bucket, Loader, or Lift Are Slow		x		x					x	x	x	
Excessive Noise From Tracks								x		x		
Excessive Noise From Bucket, Loader or Lift									x	x		
Machine Will Not Move	x	x	x	x	x	x	x	x		x	x	